

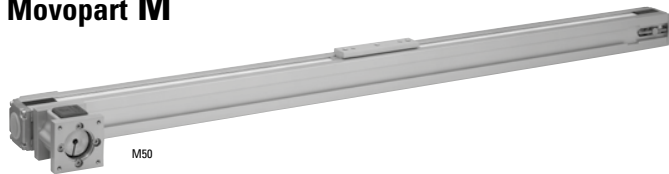

Linear Motion Systems with Belt Drive and Slide Guide

Overview

Movopart M



Features

- Can be installed in any orientation
- Patented self-adjusting prism slide guides
- Resistant to shock loads and vibrations
- Low cost

Parameter		M50
Profile size (width × height)	[mm]	50 × 50
Stroke length (Smax), maximum	[mm]	5000
Linear speed, maximum	[m/s]	5,0
Dynamic carriage load (Fz), maximum	[N]	400
Remarks		no cover band
Page		96

Movopart M

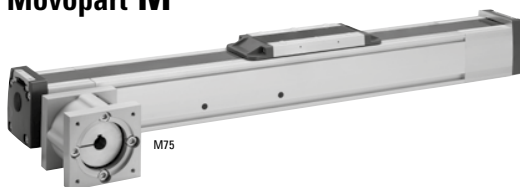

Features

- Can be installed in any orientation
- Self-adjusting stainless steel cover band
- Patented self-adjusting prism slide guides
- Wash down and enhanced wash down protected versions available

Parameter		M55	M75	M100
Profile size (width × height)	[mm]	58 × 55	86 × 75	108 × 100
Stroke length (Smax), maximum	[mm]	7000	12000	11900
Linear speed, maximum	[m/s]	5,0	5,0	5,0
Dynamic carriage load (Fz), maximum	[N]	400	1485	3005
Remarks		-	-	-
Page		98	100	102

Linear Motion Systems with Belt Drive and Slide Guide

Overview

M-Series Technical Presentation

Cover band

The self-adjusting magnetically sealed stainless steel cover band protects the unit from the penetration of dirt, dust and liquids.



Environmental protection

The standard unit can operate in harsh environments but is also available in wash down or enhanced wash down protected versions for the toughest environments.

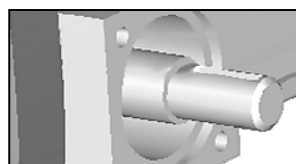
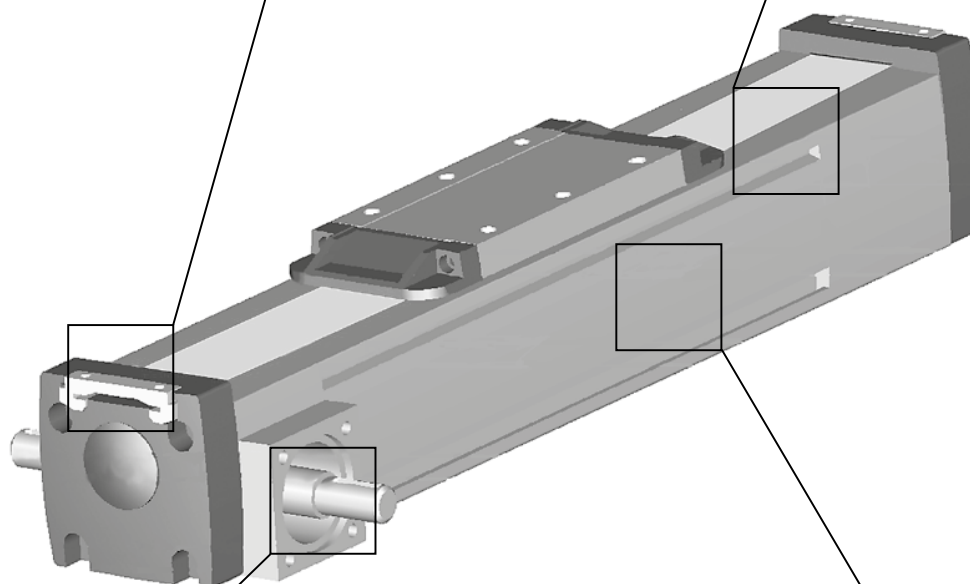
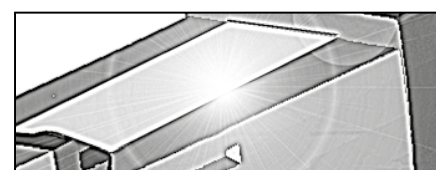

Belt drive

The belt runs on the inside of the profile and can easily be re-tensioned without removing the load from the carriage.

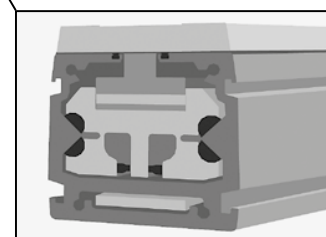

Prism slide guides

The patented self-aligning prism slide guides are accurate, durable and are resistant to vibrations and shock loads.

Note! the unit is pictured without a RediMount™ flange



M50

Belt Drive, Slide Guide

- » Ordering key - see page 206
- » Accessories - see page 131
- » Additional data - see page 180

General Specifications

Parameter	M50
Profile size (w × h) [mm]	50 × 50
Type of belt	GT 5MR-19
Carriage sealing system	none
Adjustable belt tensioning	the belt can be retensioned by the customer if necessary
Lubrication	lubricated for life
Included accessories	none

Carriage Idle Torque (M idle) [Nm]

Input speed [rpm]	Idle torque [Nm]
150	2,1

M idle = the input torque needed to move the carriage with no load on it.

Deflection of the Profile

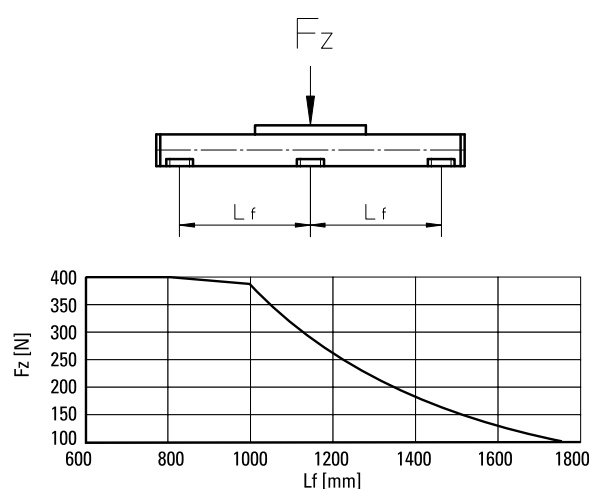

Performance Specifications

for Units with Single Standard Carriage (A00)

Parameter		M50
Stroke length (Smax), maximum	[mm]	5000
Total length (L tot), maximum	[mm]	5296
Linear speed, maximum	[m/s]	5,0
Acceleration, maximum	[m/s ²]	40
Repeatability	[± mm]	0,2
Input speed, maximum	[rpm]	2300
Operation temperature limits	[°C]	-20 – 70
Dynamic load (Fx), maximum	[N]	400
< 2,5 m/s		200
> 2,5 m/s		
Dynamic load (Fy), maximum	[N]	400
Dynamic load (Fz), maximum	[N]	400
Dynamic load torque (Mx), maximum	[Nm]	5
Dynamic load torque (My), maximum	[Nm]	21
Dynamic load torque (Mz), maximum	[Nm]	21
Drive shaft force (Frd), maximum ¹	[N]	350
Input/drive shaft torque (Mta), maximum	[Nm]	10
Pulley diameter	[mm]	41,38
Stroke per shaft revolution	[mm]	130
Weight	[kg]	
of unit with zero stroke		0,71
of every 100 mm of stroke		0,96
of carriage		0,33

¹ Only relevant for units without RediMount flange.

Definition of Forces

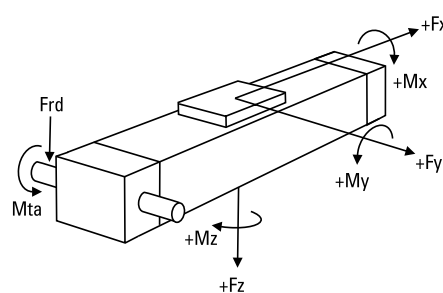

M50

Belt Drive, Slide Guide

Dimensions	Projection	Online Sizing & Selection!
METRIC		www.LinearMotioneering.com

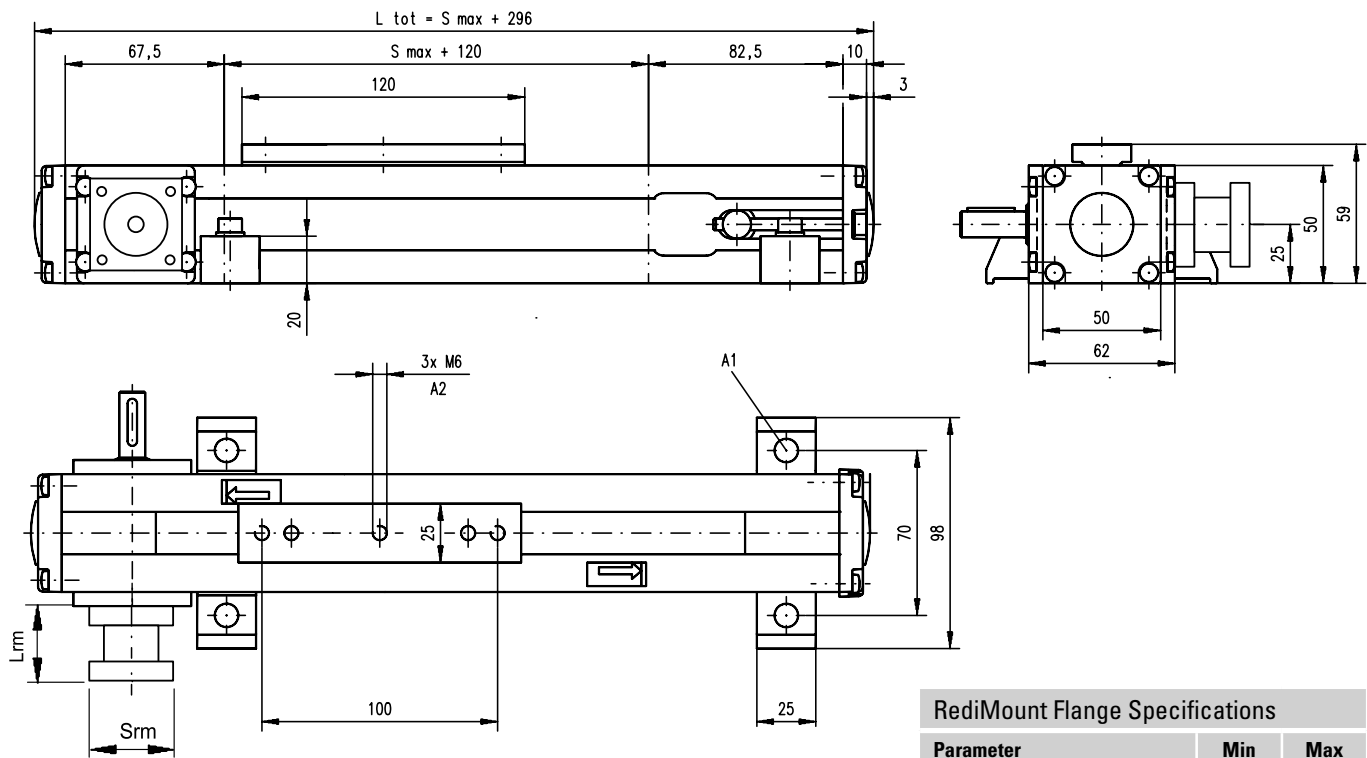

A1: $\phi 6,5$ for M6 screw
A2: depth 9, Heli coil

Parameter		Min	Max
Flange length (Lrm)	[mm]	57	92
Flange square (Srm)	[mm]	60	139
Flange weight *	[kg]	1,84	

* Max. weight including coupling and fastening screws



M55

Belt Drive, Slide Guide

- » Ordering key - see page 206
- » Accessories - see page 131
- » Additional data - see page 180

General Specifications

Parameter	M55
Profile size (w × h) [mm]	58 × 50
Type of belt	22-STD SM5-HP
Carriage sealing system	self-adjusting steel cover band
Adjustable belt tensioning	the belt can be retensioned by the customer if necessary
Lubrication	lubricated for life
Included accessories	none

Carriage Idle Torque (M idle) [Nm]

Input speed [rpm]	Single Carriage	Double Carriages
150	2,1	3,8

M idle = the input torque needed to move the carriage with no load on it.

Deflection of the Profile

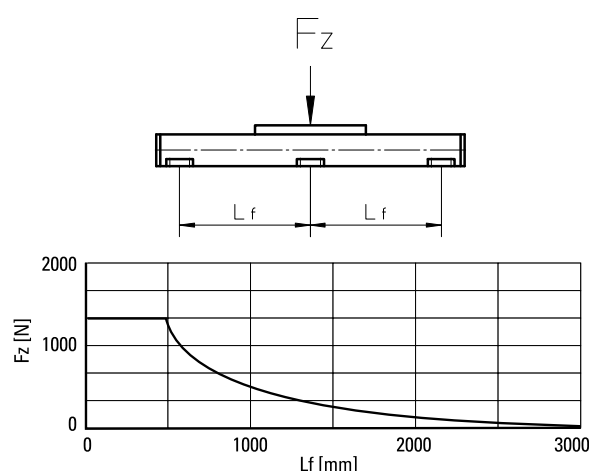

Performance Specifications

for Units with Single Standard Carriage (A)¹

Parameter		M55
Stroke length (Smax), maximum	[mm]	7000
Total length (L tot), maximum	[mm]	7313
Linear speed, maximum	[m/s]	5,0
Acceleration, maximum	[m/s ²]	40
Repeatability	[± mm]	0,2
Input speed, maximum	[rpm]	2850
Operation temperature limits	[°C]	-20 – 70
Dynamic load (Fx), maximum	[N]	400
< 2,5 m/s		200
> 2,5 m/s		
Dynamic load (Fy), maximum	[N]	400
Dynamic load (Fz), maximum	[N]	400
Dynamic load torque (Mx), maximum	[Nm]	9
Dynamic load torque (My), maximum	[Nm]	21
Dynamic load torque (Mz), maximum	[Nm]	21
Drive shaft force (Frd), maximum ²	[N]	200
Input/drive shaft torque (Mta), maximum	[Nm]	7
Pulley diameter	[mm]	33,42
Stroke per shaft revolution	[mm]	105
Weight	[kg]	
of unit with zero stroke		4,10
of every 100 mm of stroke		0,41
of carriage		1,10

¹ See next page for deviating values of units with other carriage types.

² Only relevant for units without RediMount flange.

Definition of Forces

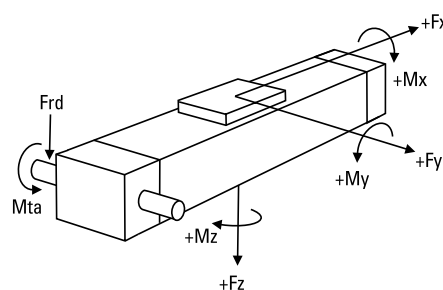

M55

Belt Drive, Slide Guide

Dimensions	Projection	Online Sizing & Selection!
METRIC		www.LinearMotioneering.com

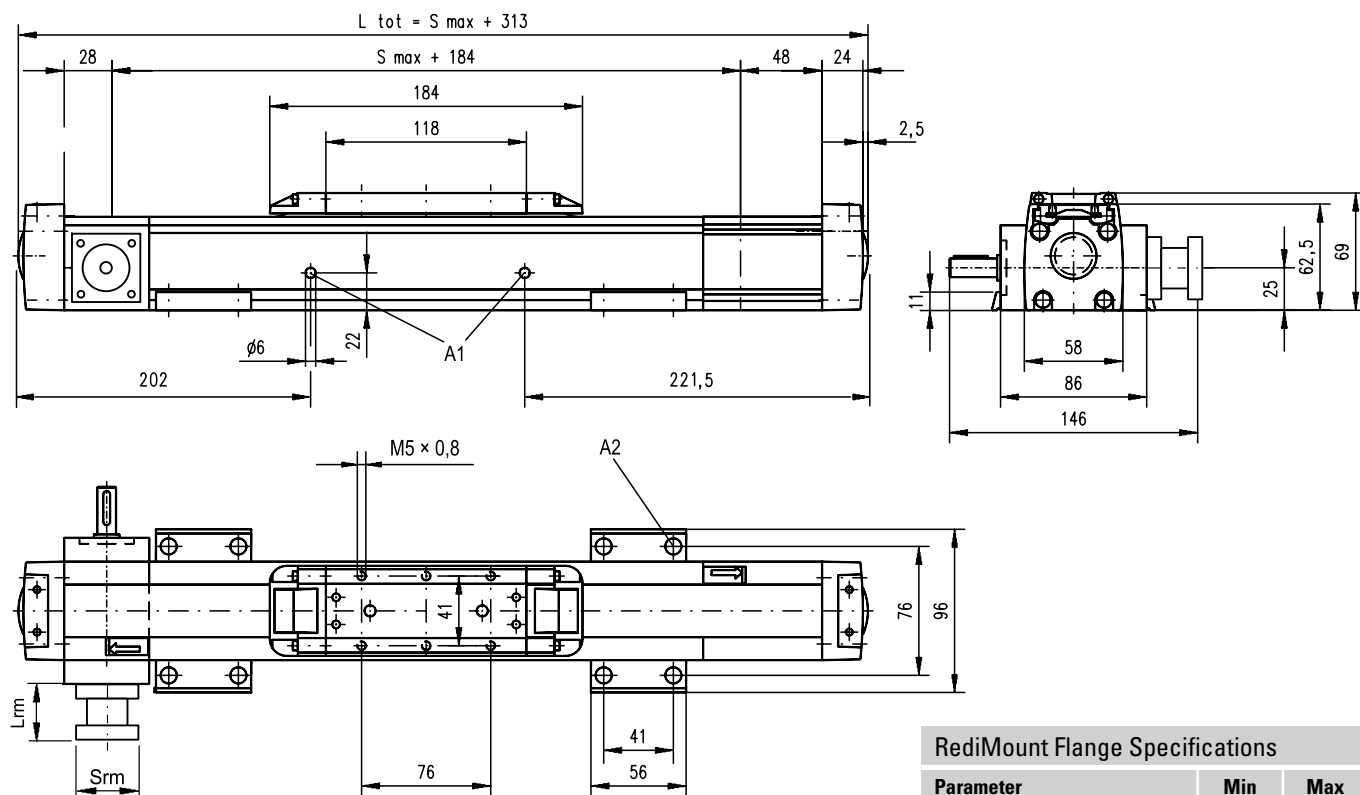

A1: slide guide tensioning holes
A2: $\phi 9,5/\phi 5,5$ for socket head cap screw M5

Parameter		Min	Max
Flange length (Lrm)	[mm]	57	92
Flange square (Srm)	[mm]	60	139
Flange weight *	[kg]	1,84	

* Max. weight including coupling and fastening screws

Parameter		M55
Stroke length (Smax), maximum	[mm]	6800
Total length (L tot), maximum	[mm]	7313
Minimum distance between carriages (Lc)	[mm]	200
Dynamic load (Fy), maximum	[N]	600
Dynamic load (Fz), maximum	[N]	600
Dynamic load torque (My), maximum	[Nm]	$Lc^1 \times 0,3$
Dynamic load torque (Mz), maximum	[Nm]	$Lc^1 \times 0,3$
Force required to move second carriage	[N]	35
Total length (L tot)	[mm]	$Smax + Lc + 313$
Weight of unit with zero stroke of carriages	[kg]	6,00 2,20

¹ Value in mm

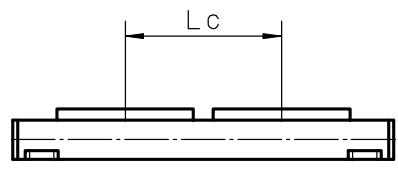



M75

Belt Drive, Slide Guide

- » Ordering key - see page 206
- » Accessories - see page 131
- » Additional data - see page 180

General Specifications

Parameter	M75
Profile size (w × h) [mm]	86 × 75
Type of belt	STD5-40
Carriage sealing system	self-adjusting steel cover band
Adjustable belt tensioning	the belt can be retensioned by the customer if necessary
Lubrication	lubricated for life
Included accessories	none

Performance Specifications

for Units with Single Standard Carriage (A)¹

Parameter		M75
Stroke length (Smax), maximum	[mm]	12000
Total length (L tot), maximum	[mm]	12368
Linear speed, maximum	[m/s]	5,0
Acceleration, maximum	[m/s ²]	40
Repeatability	[± mm]	0,2
Input speed, maximum	[rpm]	2300
Operation temperature limits	[°C]	-20 – 70
Dynamic load (Fx), maximum	[N]	
< 2,5 m/s		900
> 2,5 m/s		450
Dynamic load (Fy), maximum	[N]	1485
Dynamic load (Fz), maximum	[N]	1485
Dynamic load torque (Mx), maximum	[Nm]	49
Dynamic load torque (My), maximum	[Nm]	85
Dynamic load torque (Mz), maximum	[Nm]	85
Drive shaft force (Frd), maximum ²	[N]	600
Input/drive shaft torque (Mta), maximum	[Nm]	30
Pulley diameter	[mm]	41,38
Stroke per shaft revolution	[mm]	130
Weight	[kg]	
of unit with zero stroke		6,30
of every 100 mm of stroke		0,67
of carriage		1,50

¹ See next page for deviating values of units with other carriage types.

² Only relevant for units without RediMount flange.

Carriage Idle Torque (M idle) [Nm]

Input speed [rpm]	Single Carriage	Double Carriages
150	2,2	4,0

M idle = the input torque needed to move the carriage with no load on it.

Deflection of the Profile

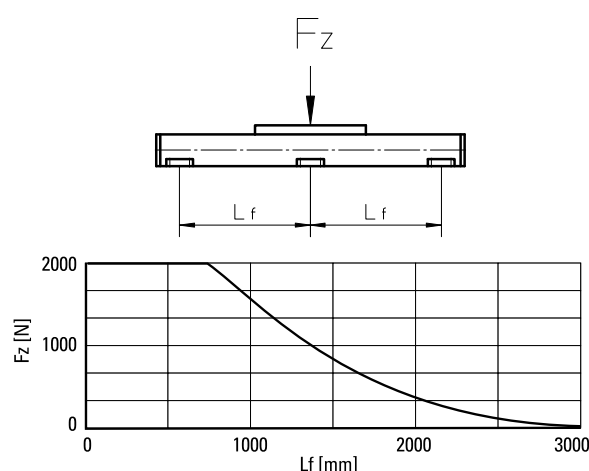

Definition of Forces

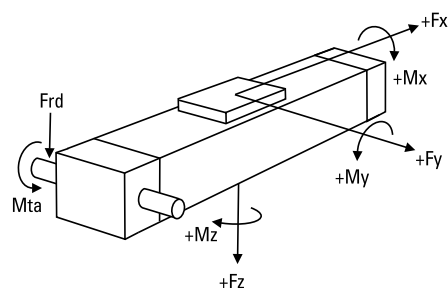

M75

Belt Drive, Slide Guide

Dimensions	Projection	Online Sizing & Selection!
METRIC		www.LinearMotioneering.com

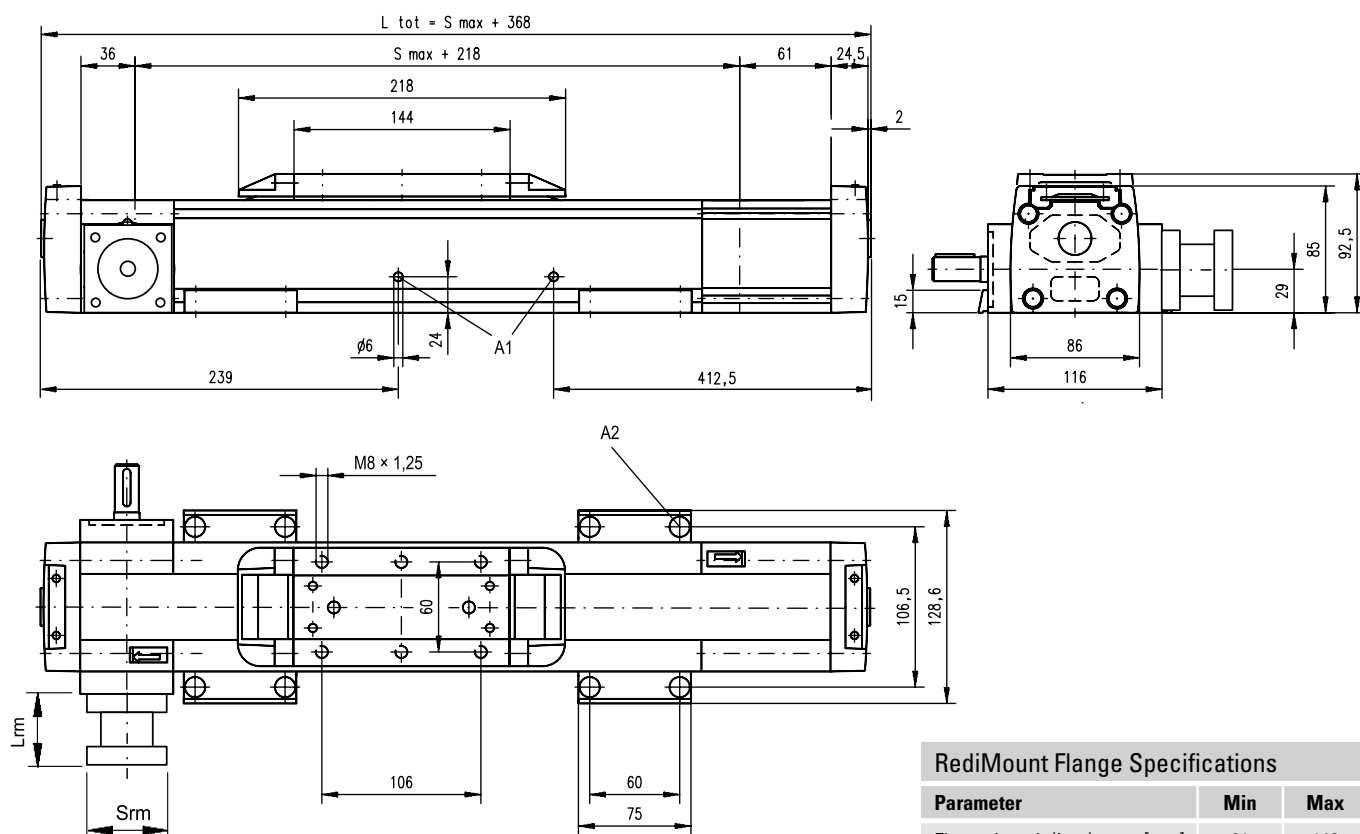

A1: slide guide tensioning holes
 A2: $\varnothing 13,5/\varnothing 8,5$ for socket head cap screw M8

Parameter	Min	Max
Flange length (Lrm) [mm]	81	143
Flange square (Srm) [mm]	90	200
Flange weight * [kg]	6,00	

* Max. weight including coupling and fastening screws

Performance Specifications

for Units with Double Standard Carriage (C)

Parameter	M75
Stroke length (Smax), maximum [mm]	11750
Total length (L tot), maximum [mm]	12368
Minimum distance between carriages (Lc) [mm]	250
Dynamic load (Fy), maximum [N]	2227
Dynamic load (Fz), maximum [N]	2227
Dynamic load torque (My), maximum [Nm]	$Lc^1 \times 1,114$
Dynamic load torque (Mz), maximum [Nm]	$Lc^1 \times 1,114$
Force required to move second carriage [N]	40
Total length (L tot) [mm]	$Smax + Lc + 368$
Weight of unit with zero stroke of carriages [kg]	9,50
	3,00

¹ Value in mm

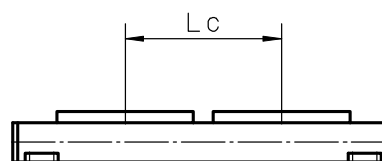



M100

Belt Drive, Slide Guide

- » Ordering key - see page 206
- » Accessories - see page 131
- » Additional data - see page 180

General Specifications

Parameter	M100
Profile size (w × h) [mm]	108 × 100
Type of belt	STD8-50
Carriage sealing system	self-adjusting steel cover band
Adjustable belt tensioning	the belt can be retensioned by the customer if necessary
Lubrication	lubricated for life
Included accessories	none

Carriage Idle Torque (M idle) [Nm]

Input speed [rpm]	Single Carriage	Double Carriages
150	3,8	5,8

M idle = the input torque needed to move the carriage with no load on it.

Deflection of the Profile

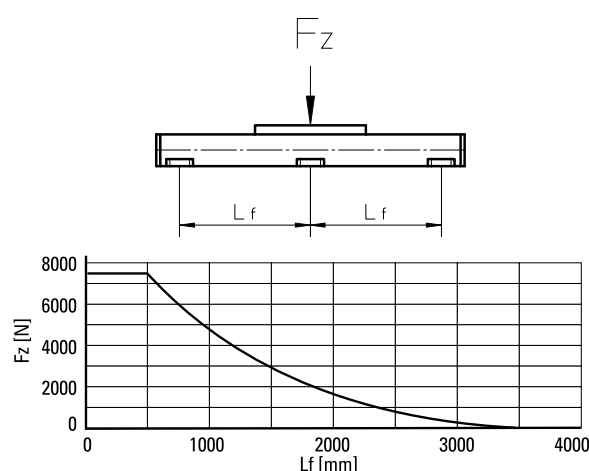

Performance Specifications

for Units with Single Standard Carriage (A)¹

Parameter		M100
Stroke length (Smax), maximum	[mm]	11900
Total length (L tot), maximum	[mm]	12331
Linear speed, maximum	[m/s]	5,0
Acceleration, maximum	[m/s ²]	40
Repeatability	[± mm]	0,2
Input speed, maximum	[rpm]	1700
Operation temperature limits	[°C]	-20 – 70
Dynamic load (Fx), maximum	[N]	
< 2,5 m/s		1250
> 2,5 m/s		625
Dynamic load (Fy), maximum	[N]	3005
Dynamic load (Fz), maximum	[N]	3005
Dynamic load torque (Mx), maximum	[Nm]	117
Dynamic load torque (My), maximum	[Nm]	279
Dynamic load torque (Mz), maximum	[Nm]	279
Drive shaft force (Frd), maximum ²	[N]	1000
Input/drive shaft torque (Mta), maximum	[Nm]	45
Pulley diameter	[mm]	56,02
Stroke per shaft revolution	[mm]	176
Weight	[kg]	
of unit with zero stroke		11,10
of every 100 mm of stroke		1,16
of carriage		2,40

¹ See next page for deviating values of units with other carriage types.

² Only relevant for units without RediMount flange.

Definition of Forces

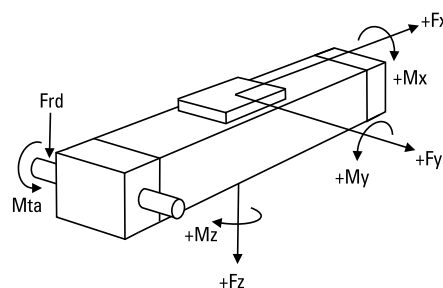

M100

Belt Drive, Slide Guide

Dimensions	Projection	Online Sizing & Selection!
METRIC		www.LinearMotioneering.com

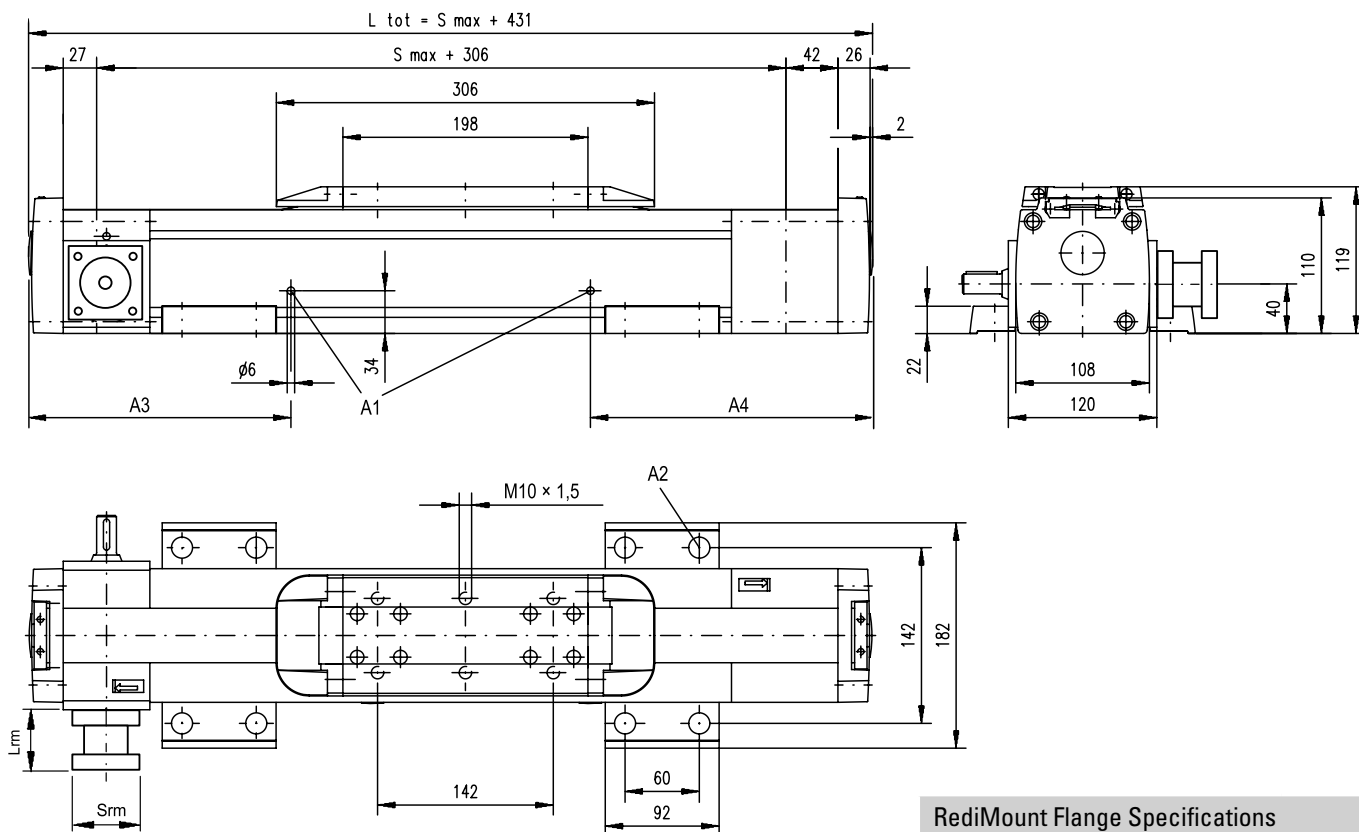

- A1: slide guide tensioning holes
- A2: $\phi 17/\phi 10,5$ for socket head cap screw M10
- A3: 170 (L tot \leq 1056 mm), 270 (L tot $>$ 1056 mm)
- A4: 186 (L tot \leq 1056 mm), 436 (L tot $>$ 1056 mm)

Parameter	Min	Max
Flange length (Lrm)	[mm] 81	143
Flange square (Srm)	[mm] 90	200
Flange weight *	[kg]	6,00

* Max. weight including coupling and fastening screws

Performance Specifications

for Units with Double Standard Carriage (C)

Parameter	M100
Stroke length (Smax), maximum	[mm] 11550
Total length (L tot), maximum	[mm] 12331
Minimum distance between carriages (Lc)	[mm] 350
Dynamic load (Fy), maximum	[N] 4508
Dynamic load (Fz), maximum	[N] 4508
Dynamic load torque (My), maximum	[Nm] $Lc^1 \times 2,254$
Dynamic load torque (Mz), maximum	[Nm] $Lc^1 \times 2,254$
Force required to move second carriage	[N] 45
Total length (L tot)	[mm] $Smax + Lc + 431$
Weight of unit with zero stroke of carriages	[kg] 17,40 4,80

¹ Value in mm

